

Owner's Guide to Cover Safety and Operation

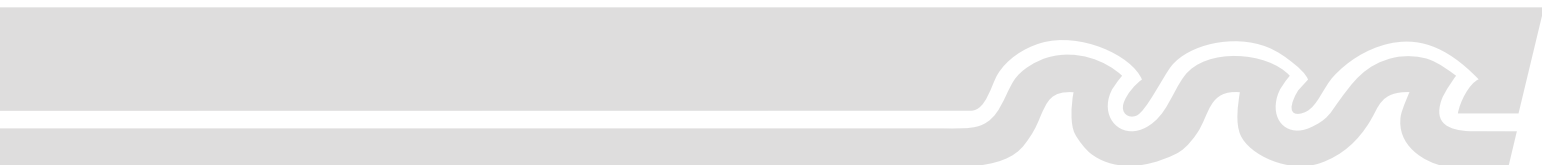

Important Safety Instructions	2
Care and Maintenance	2
Frequently Asked Questions	3
Diagnostics and Service	3
System Glossary.....	4
Prior to Opening or Closing Your Cover	5
Cover Operation - PowerTouch.....	5
Cover Operation - Key Switch.....	6
Manually Securing a Cover	6
Limited Warranty.....	7
System Information, Notes & History	8



IMPORTANT SAFETY INSTRUCTIONS



DO NOT ATTEMPT TO CONNECT, OR DISCONNECT, THE CONTROL UNIT OR MOTOR HARNESS WHILE SUPPLY POWER IS ON. DOING SO CAN IRREVERSIBLY DAMAGE CONTROLLER AND COVER MOTOR, AND POTENTIALLY CAUSE SERIOUS INJURY OR DEATH.

READ AND FOLLOW ALL INSTRUCTIONS

WARNING: To reduce the risk of injury, do not permit children to use this product unless they are closely supervised at all times.

- Whenever possible, cover should only be operated by an adult or pool owner.
- Keep children away from cover. Children or objects cannot be seen under the cover.
- Do not walk on the cover except for emergency purposes only.
- Keep the pump on the cover and set up for proper use whenever the cover is closed.
- Always keep water pumped off of the cover to avoid drowning risk.
- Keep all electrical cords and submersible pump away from the swimming area while swimming.
- Check cover for deterioration.
- Do not close the cover until all swimmers and toys are out of the pool/spa.
- Never leave your cover partially opened. Entrapment is possible.

SAVE THESE INSTRUCTIONS

CARE AND MAINTENANCE

SUBMERSIBLE PUMP

- Pump must be plugged into a G.F.C.I. protected outlet only.
- Inspect the pump periodically for wear. Frayed cords may allow water into the housing causing malfunction. Keep the pump clear of debris.

COVER

- Ensure that all debris and water is routinely removed.
- Your cover should not be operated in temperatures below 40° F.
- Your cover should not be operated if the water level is below the skimmer. This will cause the cover to strain and potentially damage the system.
- When winterizing, the water level should be NO LOWER THAN 1"-2" below the skimmer. The cover has slack to accommodate this winter level.
- Ladders, (if applicable) must be removed or hinged so they can be raised before the cover is closed.
- When adding chemicals, the cover should remain open for at least two hours to allow chemicals to disburse. Concentration of chemical and chemical gases in the water might cause premature aging of the fabric. Be sure to maintain supervision any time the cover is open.

VINYL FABRIC

- When the fabric begins to show wear due to chemicals, age, heat and sun, it will become brittle and may compromise the safety aspect of the fabric. When the fabric reaches this point, it should be replaced. Contact your dealer at this time.
- Inspect for holes in fabric. The fabric can easily be patched. Call for service or a patch kit.
- Inspect the webbing (the material that runs in the tracks). If the stitching begins to tear or fray, the strength of the cover may be compromised.
- Open your cover at least once a week during the swimming season to allow the water to breathe. **Maintain supervision any time the cover is open.**

TRACKS

- Inspect the screws that secure the deck/coping (if applicable). If they become loose, tighten the screws with a screwdriver.
- Spray water into the track channel two times per year to remove potential debris buildup. (Spring and Autumn).

MECHANISM

- The mechanism is designed to be maintenance free; however, the recessed box the cover rolls into should be cleaned out at least once per year. Leaves and debris from inside the box can be "picked up" by the fabric and deposited into your water.
- A system maintenance should be performed by a trained service technicians either annually or bi-annually. This service typically includes cleaning out the recessed box, an overall tune up of the system and a complete safety check.
- When installed properly, the recessed box will allow water to drain. Water in the recessed box may cause undue wear, additional drainage may be needed if this problem arises.
- Turn power off to the system off while the pool is closed for the season.

FREQUENTLY ASKED QUESTIONS

1. Can I walk on the cover?

Although you can, we recommend you only walk on the cover in an emergency.

2. There seems to be a lot of slack in the cover, is it too big?

The fabric is manufactured to include extra material. The fabric may appear wrinkled or oversized but that is normal and they may smooth out.

3. Can the cover be opened/closed manually?

Yes, it can. Please refer to the "Manually Securing Your Cover" section of this manual, or contact your pool cover service company.

4. If I drain my pool/spa or if the water leaks out, should I close the cover?

No! Closing the cover when the water level is any more than 6" below the skimmer could cause damage to the system. The system is designed for the level of the water to support the cover.

5. The cover is opening/closing crooked, what should I do?

If the cover opens or closes more than 2" off in normal position, then an adjustment is needed. This should be accomplished by a trained technician. Please contact your pool cover service company.

6. Should I leave the cover pump on the cover at all times?

The cover pump should be left on when the cover is closed. The only exception is during severe winter conditions. If it is too cold to melt the ice and snow on the cover, pull the pump off and place it in a warm area. Place the pump back on when the ice begins melting.

7. Sometimes I hear a "popping noise" when I open/close the cover...is that normal?

This noise is caused when the ropes pass through the different pulleys and onto the rope reel. This is normal and not an indication of trouble.

DIAGNOSTICS AND SERVICE

1. The cover does not open/close when I activate the controller.

- Check wire connections.

2. Water appears on my cover when it has not rained in days

- Your cover may have a hole and needs to be patched. Please contact your pool cover service company for a patch kit to easily fix the problem.

3. The cover stops half way closed/opened.

- The tracks might have dirt or debris inside. Clean the tracks out with water.
- The ropes could be tangled around the rope reel. Lift the lid, if the rope appear to be tangled, call for service or carefully attempt to untangle ropes.
- There is too much water or an obstruction. Pump the water off the cover. If problem continues, the torque may need to be adjusted.

4. The controller indicator light is blinking red.

- This means the cover has stopped under stress. There might be too much water on the cover. The cover could be running crooked or there could be an object blocking the cover. Remove the water or blocking object. If red light continues to blink, call for service.
- Torque level is too low. Contact Automatic Pool Covers, Inc. technical support at (800) 878-5789, or your local service provider.

5. The cover is completely open and will not close.

- If the green indicator light is NOT on, you do not have power to the system. Check your electrical service, or make sure that your code is correct.

6. Submersible cover pump is not pumping off the water.

- The automatic shut-off may be malfunctioning. Check your pump-owner's manual for troubleshooting tips.

7. My controller does not light up.

- Check for power.
- Make sure that your code is correct (*PowerTouch only*).

SYSTEM GLOSSARY

To help understand the different components of automatic pool cover systems, this illustration shows the major components of the system and their function. This is a basic layout, your system may vary slightly.

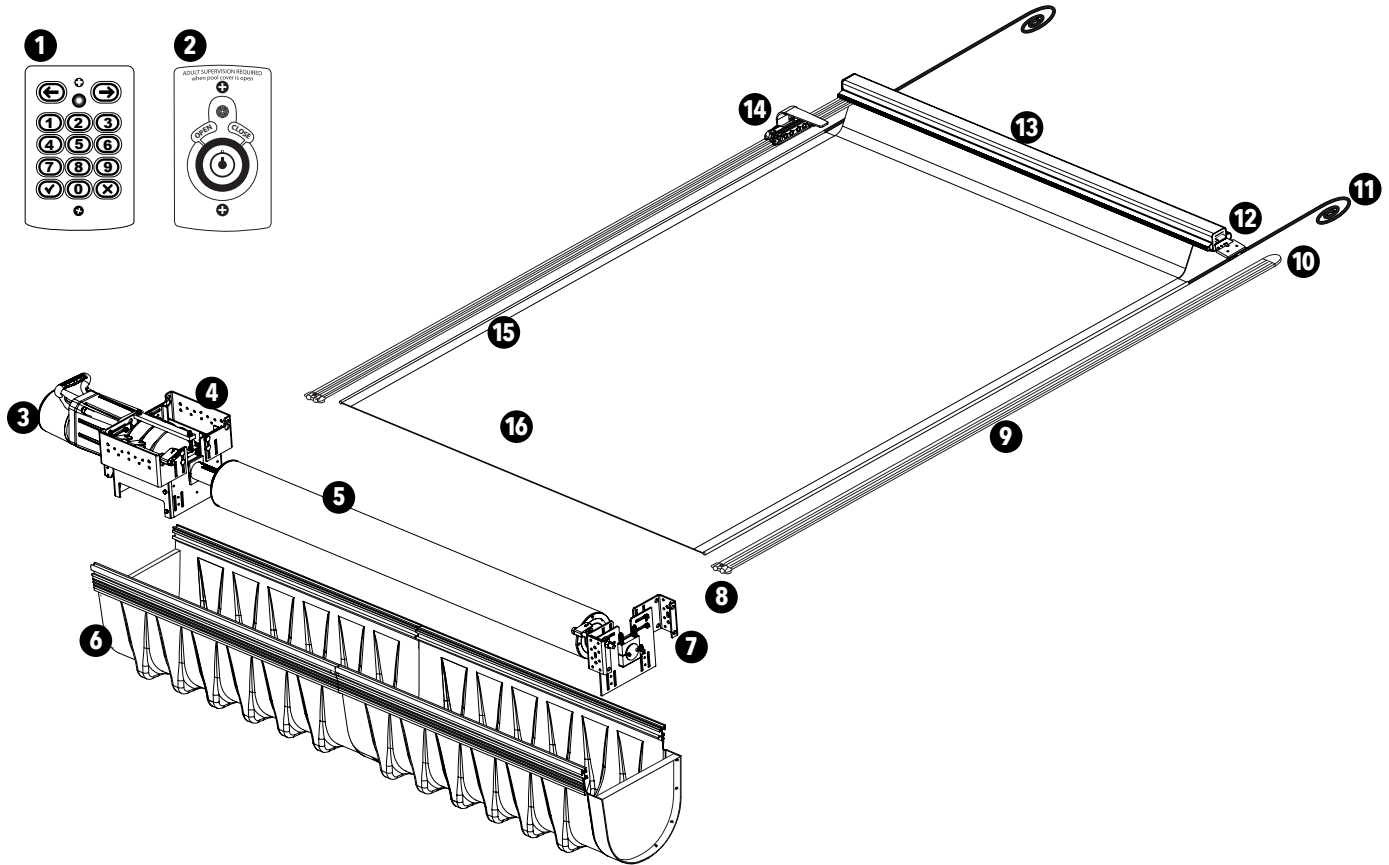

- 1** POWER TOUCH™ TOUCH PAD CONTROLLER†
- 2** KEY SWITCH CONTROLLER†
- 3** MOTOR - drives the system
- 4** MECHANISM END - the end that has the motor
- 5** TUBE - what the cover rolls up on
- 6** POLYMER BOX (alternately wood or concrete) - holds unit
- 7** OPPOSITE END - non-motor end
- 8** ROPE GUIDE - transitions the rope from the track to the reel

†Your system has one kind of controller or the other

- 9** TRACK - what the rope and cover/webbing run inside
- 10** PULLEY CASTING - where the rope turns around at the far end
- 11** ROPE - connected to cover; runs inside the track
- 12** GLIDER & BRACKET† - connects the rope to the lead edge
- 13** LEAD EDGE^S - the front edge of the pool cover
- 14** CARRIAGE & BRACKET† - connects the rope to the lead edge
- 15** WEBBING - section of material connected to the edge of the cover
- 16** COVER - the vinyl that protects the pool

†Your system has one type of bracket or the other
^SYour Lead Edge may be square or round

TRACK - There are different styles of Automatic Pool Covers tracks:

- A** TOP TRACK - mounted to the surface of the pool decking
- B** FLUSH TRACK - recessed in the surface of the pool decking
- C** UNDER TRACK - mounted under the pool decking (2 & 3 channel)

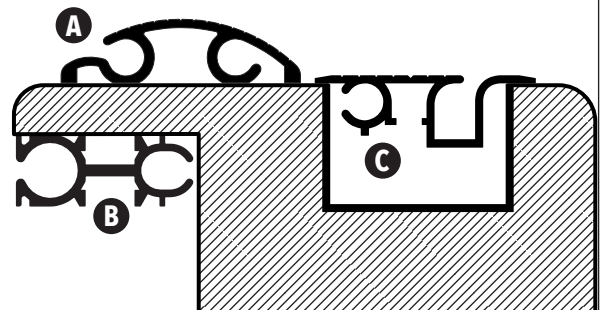

PRIOR TO OPENING OR CLOSING YOUR COVER

- Check and clear obstructions (towels, ladders, sports equipment, toys, pool furniture, etc.).
- Check to ensure swimmers are not in the pool/spa during opening and closing of the cover.
- Check cover for water or debris (leaves, etc.) and remove with cover pump or pool brush.
- Ensure that you are familiar with all the safety instructions.
- Remove the cover pump after pumping off water.

COVER OPERATION - POWER TOUCH

The indicator light must illuminate **BLUE**, indicating power is applied to the cover system.

OPENING THE COVER

- Remove the cover pump after pumping off water.
- Activate your controller, then type 4 digit code and press (✓).
- Press and hold the **OPEN** button (←) or (→).
- The indicator light will flash **GREEN** while the cover is moving.
- When the cover is fully opened, the keypad's electronics will stop the cover and the indicator will flash **RED**.
- Release (←) or (→). The indicator light will turn a solid **GREEN**.
- To reduce risk of damage, release **OPEN** button prior to reaching the hard stops.
- Press (X) to turn off the controller, or let it rest for 10 seconds.

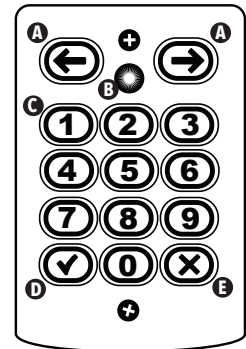

A. Direction B. Indicator Light
C. Number Keys D. Enter
E. Cancel/Exit

CLOSING THE COVER

- Activate your controller, type in the 4 digit code then press (✓).
- Press and hold the **CLOSE** button (←) or (→).
- The indicator light will flash **GREEN** while the cover is moving.
- When the cover is completely closed, the electronic torque limit feature will stop the cover. The indicator light will flash **RED**.
- Release (←) or (→). The indicator light will turn a solid **GREEN**.
- To reduce risk of damage, release prior to reaching the hard stops.
- Press (X) to turn off the controller, or let it rest for 10 seconds.
- Place cover pump on the spa cover and plug it into a G.F.C.I. electrical outlet.

CHANGING YOUR CODE

To change the default code set at the factory (1 2 3 4) or to change the code after you have set a custom code:

1. Press and hold (✓) until **RED** light glows.
2. Enter new desired 4 digit code.
3. The **RED** light will turn off when the new code has been accepted. The controller is ready for normal use.

COVER OPERATION - KEY SWITCH

The keyswitch indicator light glows **GREEN** which denotes that power is applied to the cover system.

KEYSWITCH INDICATOR LIGHT MEANINGS

- Solid **GREEN** Light - System has power and is ready for operation
- Flashing **GREEN** Light - System is moving
- Flashing **RED** Light - Cover has stopped due to a strain on motor
- Solid **RED** Light - Cover is completely opened or closed.

PRIOR TO OPENING/CLOSING THE COVER

- Be sure the keyswitch light is glowing **GREEN**, there is power to the cover system.
- (OPENING) Remove all water off the cover and remove the cover pump.
- (CLOSING) Be sure all swimmers have exited the pool and that pool is empty.

OPENING/CLOSING THE COVER

- Insert key and turn it to the **LEFT** to **OPEN** cover or to the **RIGHT** to **CLOSE** the cover.
- The light will blink **GREEN** and the cover will begin to move.
- Keep constant pressure on the key during the OPEN/CLOSE procedure.
- When the cover is completely OPENED/CLOSED, the indicator light will turn from **GREEN** to **RED**.
- When the key is released, the light will turn **GREEN** again.

NOTE: If the light begins to flash **RED** during the OPEN/CLOSE procedure, the cover has stopped due to a strain on the motor. Release key and troubleshoot. Clear any obstructions. After 10 seconds, system will reset and the light should glow **GREEN**. If flashing **RED** light continues, turn power off and back on to reset system. If **RED** light continues flashing, call for service.

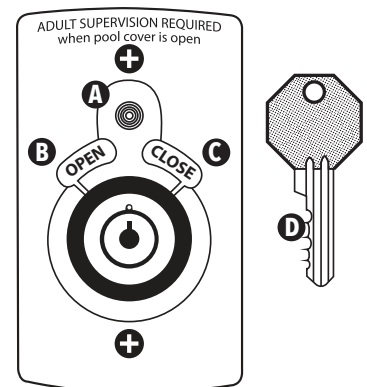

A. Indicator Light B. Open
C. Close D. Key

MANUALLY SECURING YOUR COVER



IMPORTANT



NEVER LEAVE POOL UNCOVERED WITHOUT ADULT SUPERVISION.

TO PREVENT A DROWNING HAZARD, THE AUTOMATIC COVER CAN BE CLOSED MANUALLY IF THE POOL COVER CONTROL SYSTEM BECOMES INCAPACITATED WHILE THE POOL COVER IS OPEN.

IMPORTANT NOTE

- *These instructions are for AUTOMATIC POOL COVERS, INC. systems.*
- *Complete steps 1 through 9 for an **AutoGuard** cover system by Automatic Pool Covers, Inc.*
- *Complete steps 5 through 9 for an **AutoGuard Mini** cover system by Automatic Pool Covers, Inc.*

- Step 1** Turn off power supply to cover system.
- Step 2** Remove the lid or housing cover in order to access the mechanical components of the cover system. These are located on the right or left side of end of the pool where the cover rolls up.
- Step 3** Locate the motor coupler assembly which attached the motor to the cover mechanism.
- Step 4** Using a 9/16" wrench (socket wrench with extension works best), remove the two coupler bolts which hold the coupler together. This will eliminate resistance on the cover from the idle motor.
- Step 5** Locate the ropes and the reel they are wound onto.
- Step 6** Pull the ropes upward incrementally, unwinding the reel, until the ropes are at their end.
- Step 7** Unfasten the ropes from both of the reels.
- Step 8** With both ropes free from reel, establish a good grip in the same spot on each rope and pull. The cover should move.
- Step 9** Use controlled movements, moving the cover a few feet on each pull, making sure to keep even tension on both ropes so the cover stays straight. Reset grip on the rope if necessary between pulls.

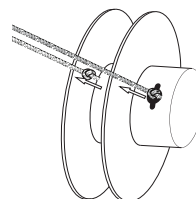
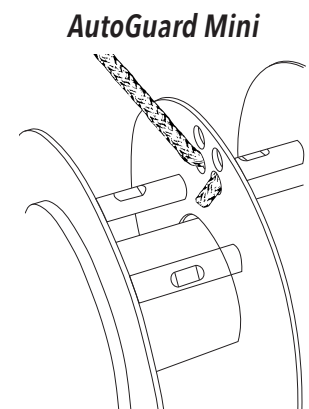
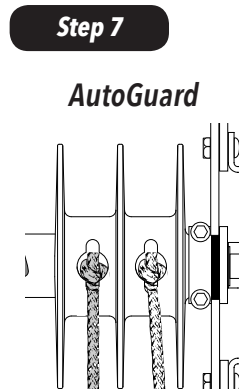
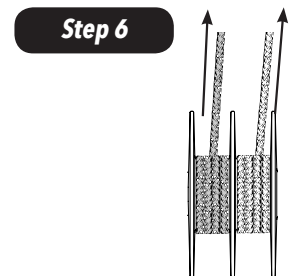
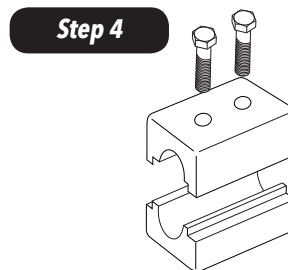
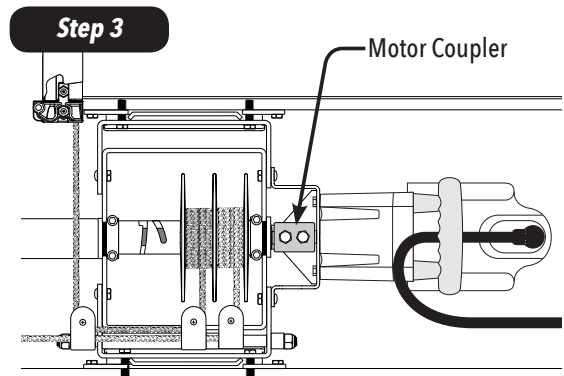

Please contact your pool cover service company or call Automatic Pool Covers, Inc. Technical Support at (800) 878-5789 if you need assistance with this procedure.

LIMITED WARRANTY

MECHANICAL AND ELECTRICAL

Automatic Pool Covers, Inc. warrants the Mechanical and Electrical components to be free from defects in material or workmanship which results in failure of the component and/or an inoperable Cover System.

MECHANICAL COMPONENTS TERMS AND CONDITIONS:

The Mechanical Components Limited Warranty Period is ten (10) years or one-hundred-twenty (120) months from the shipment date of the Mechanical Components from Automatic Pool Covers, Inc. Automatic Pool Covers, Inc. will replace or repair the Mechanical Components and include return shipping costs from Automatic Pool Covers, Inc. during the Limited Warranty Period. The Mechanical Components Limited Warranty does not include pulleys, guides, lead edge gliders or custom items.

ELECTRICAL COMPONENTS TERMS AND CONDITIONS:

The Electrical Components Limited Warranty Period is three (3) years or thirty-six (36) months from the shipment date of the Electrical Components from Automatic Pool Covers, Inc. Automatic Pool Covers, Inc. reserves the right to replace or repair the Electrical Components and include return shipping costs from Automatic Pool Covers, Inc. during the Limited Warranty Period.

MECHANICAL AND ELECTRICAL COMPONENTS LIMITED WARRANTY CONDITIONS:

Components are treated as individual parts of the System, and they are each covered individually, not wholly. The Limited Warranty does not include any travel or labor costs for replacement or repair of warranted parts from Automatic Pool Covers, Inc. to the Pool Cover Dealer, Distributor or Pool Cover Owner.

- The Limited Warranty does not cover shipping costs of Components to Automatic Pool Covers, Inc.
- The Limited Warranty does not cover incidental or consequential damages.
- The Limited Warranty is not valid if full payment has not been received by Automatic Pool Covers, Inc. in accordance with the original terms and conditions of sale prior to warranty claim.

The Limited Warranty does not cover the following: Acts of God such as storm or flood, snow damage, operation of the Cover System with frozen water and/or in temperatures below forty (40) degrees Fahrenheit, inadequate pool water level, or due to user abuse, improper installation, improper chemical balance, or failure to comply completely with the Manufacturer's Installation and Owner's Manual guidance.

All Limited Warranty Claims must be pre-authorized by Automatic Pool Covers, Inc. and Components are required to be returned to Automatic Pool Covers, Inc. for warranty determination. Replacement Components will carry the balance of the original warranty.

COVER FABRIC

Automatic Pool Covers, Inc. warrants the Cover Fabric ("Fabric") material free from defects due to excessive shrinkage or deterioration whereby the Fabric is unable to prevent a volume of pool water from penetrating through the bottom of the Fabric or which results in an inoperable Cover System.

The Cover Fabric Material Limited Warranty Period is five (5) years or sixty (60) months from the ship date of the Fabric from Automatic Pool Covers, Inc to the Pool Cover Dealer or Distributor. Automatic Pool Covers, Inc. reserves the right to replace or repair the Fabric Material and include return shipping costs from Automatic Pool Covers, Inc during the first three (3) years or thirty-six (36) months of operation if defects in the Fabric are due to excessive shrinkage or deterioration of the Fabric where the Fabric is unable to prevent a volume of pool water from penetrating up through the bottom of the Fabric and which results in an inoperable Cover System.

Automatic Pool Covers, Inc. will replace or repair the Fabric Material in the fourth (4th) through fifth (5th) year, or thirty-seventh (37th) month through the sixtieth (60th) month of the Warranty Period, on a replacement cost basis including return shipping costs from Automatic Pool Covers, Inc. The material replacement cost will be reduced by one-sixtieth (1/60th) per month for each remaining month of warranty. The automatic or manual pool Cover System must have been installed and operated in accordance with the Manufacturer's Installation and Owner's Manual in order to qualify for a warranty claim.

FABRIC LIMITED WARRANTY CONDITIONS:

Vinyl, ropes and hybrid-webbing are treated as individual parts of the Fabric, while all are covered under the Limited Warranty they are each covered individually, not wholly.

- The Limited Warranty does not include any travel or labor costs for replacement or repair of warranted parts from Automatic Pool Covers, Inc. to the Pool Cover Dealer, Distributor or Pool Cover Owner.
- The Limited Warranty does not cover shipping costs to Automatic Pool Covers, Inc.
- The Limited Warranty does not cover incidental or consequential damages.
- The Limited Warranty is not valid if full payment has not been received by Automatic Pool Covers, Inc. in accordance with the original terms and conditions of sale prior to warranty claim.
- The Limited Warranty does not cover the following: Acts of God such as storm or flood, snow damage, operation of the Cover System with frozen water and/or in temperatures below forty (40) degrees Fahrenheit, inadequate pool water level, or due to user abuse, improper installation, improper chemical balance, normal fading of Fabric color, or failure to comply completely with the Manufacturer's Installation and Owner's Manual guidance.

All Limited Warranty Claims must be pre-authorized by Automatic Pool Covers, Inc. and components are required to be returned to Automatic Pool Covers, Inc. for warranty determination. If Fabric is replaced within the first 36 months, the replacement Fabric will carry the balance of the original warranty.

